

EXPANDED PTFE JOINT SEALANT

FLONTAPE TYPE MOAX



- ▶ FLONTAPE MOAX is made from 100 % pure expanded PTFE (ePTFE).
- ▶ The universal gasketing forms a thin, but yet strong, reliable gasket under compression, that is highly resistant to aggressive media and chemically inert.
- ▶ Even for the sealing of large, complex and damaged flanges - just peel of the covering paper from the adhesive backing and stick the gasketing to the sealing surface - overlap the ending and close the jointing.
- ▶ You will see how FLONTAPE MOAX reduces maintenance time, loss production and total sealing costs.
- ▶ FLONTAPE MOAX is the economic sealing solution for all standard applications.

Typical Applications

Components

expansion joints, machine housing, apparatus flanges, hand and manholes (for TRD 401 please contact our technical service)

Flanges

All types of flanges, large and complex geometries

Sealing Areas and Flange Materials

steel, aluminium, graphite, rubber lined components

Key Features

- 100 % pure expanded PTFE (ePTFE)
- chemically inert (for use with alkali metals and elemental fluorine ask our technical service)
- highly compressible
- easy and quick installation
- reliable and long lasting
- ideal for large and complex sealing surfaces
- reduces scrap and sealing costs

Technical Data

Material

100 % pure, virgin, expanded PTFE

Temperature Resistance of the Sealing Material

-240°C to +270°C, intermittent to +315°C

Chemical Resistance

Chemical resistance to all media pH 0 to 14, except molten alkali metals and elemental fluorine

Recommended Application Range

Temperature: up to 150 °C

Pressure: Vacuum to 40 bar (580 psig)

depending on the installation parameters higher figures can be achieved

Approvals and Safety

Tested according to TÜV MUC-KSP-A066

complies with: DVGW VP 403

FDA 21 CFR 177.1550 (PTFE)

FDA 21 CFR 175.105 (adhesive)

Characteristics

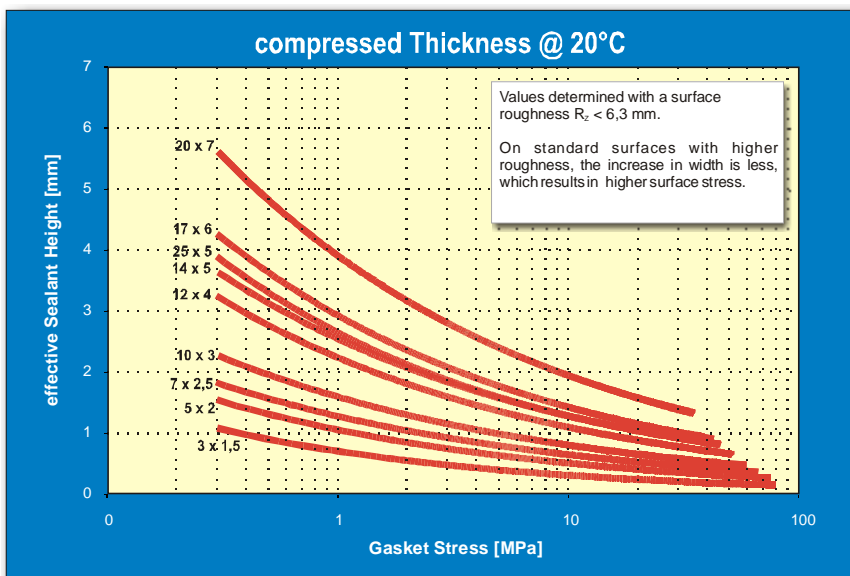
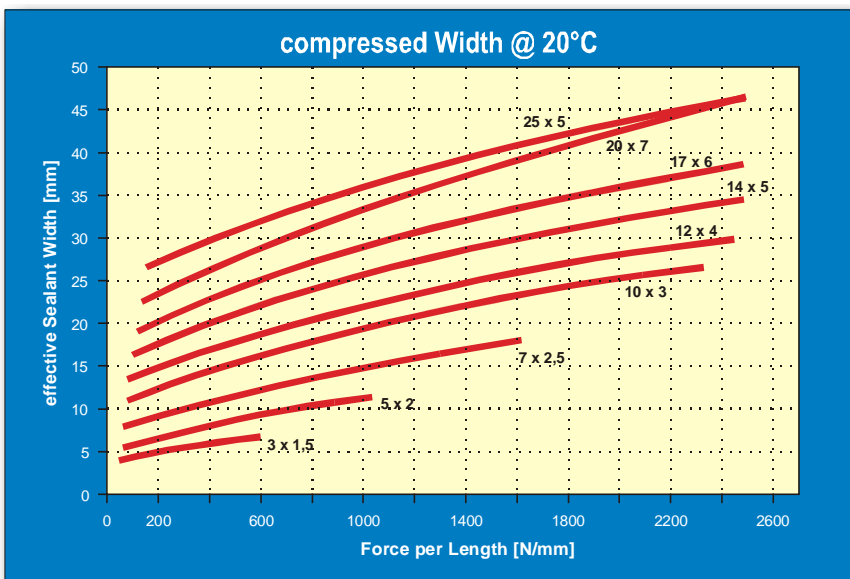

FLONTAPE MOAX Sizes

Size (mm)	Spool Length				
	5 m	10 m	25 m	30 m	50 m
3 x 1,5			(x)	x	(x)
5 x 2			x		(x)
7 x 2,5			x		(x)
10 x 3		X	(x)		(x)
12 x 4		(x)	(x)		(x)
14 x 5	x	(x)	x		
17 x 6	x	(x)	x		
20 x 7	x	(x)	x		
28 x 5	(x)	(x)			
40 x 5	(x)	(x)			



x = standard dimension
 (x) = available on request

Installation

Completely clean the sealing area and remove any dirt, corrosion, oil or leftover from old gasket material.

Cut one ending of the sealing tape and remove just a little of the protecting paper. Place the tape at the nearest possible position next to the bolts, starting next to a bolt hole. Fit the gasket around the entire flange circumference and cross the endings as shown in figure 1.

Assembled in fragile flanges apply techniques as shown in figure 2. Skive the endings as shown in figure 3 and overlap according to the recommended overlap length. Cut off the excess, tapering to the end, leaving a total thickness of approx. 120 %.

At least 4 progressive torque sequences with a torque wrench, in a star of 180° (fig. 1), should follow the first torque by hand.

Lastly perform a circular torque to check and ensure a tight and long-lasting seal.

Fig. 1 - Assembly in standard jointing

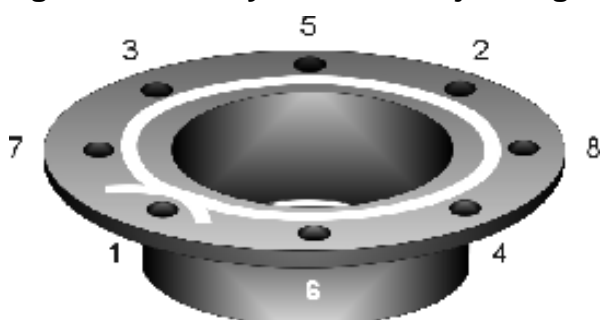

Fig. 2 – Assembly in fragile jointing

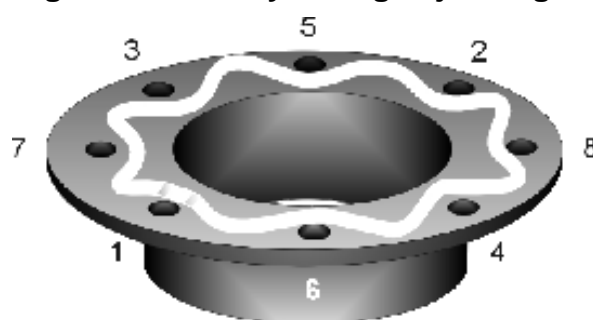
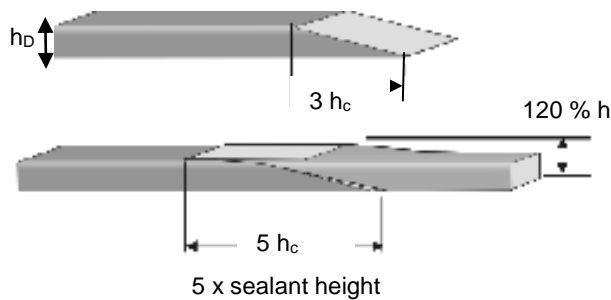

Fig. 3 - Assembly with skiving technique in fragile flanges and sizes > 17 x 6 mm



Torquetable for DIN-Flanges

with Gaskets according to EN1514-1

Nominal Bore DN	Torque [Nm]					
	Plastics Flanges PN 10	Steel Flanges				
		PN 6	PN 10	PN 16	PN 25	PN 40
10	6	25	43	43	43	43
15	7	25	43	43	43	43
20	10	25	43	43	43	43
25	15	25	43	43	43	43
32	25	43	90	90	90	90
40	30	43	105	105	105	105
50	40	43	105	105	105	105
65	50	43	105	105	105	105
80	30	105	105	105	105	105
100	35	105	105	105	200	200
125	45	105	105	105	350	350
150	60	105	205	205	350	350
200	85	105	205	205	350	410
250	65	105	205	350	525	710
300	75	205	205	350	525	710

With the use of DIN Gaskets according to EN 1514-1, the a/m torque moments lead to a size-relating gasket stress at assembly of approx: 10 MPa for plastics flanges / 30 MPa for steel flanges (friction coefficient 0,14 - regular bolts grade 5.6).

Higher gasket stress causes better leakage rates of the sealing system and higher blow out safety!

Higher gasket stress causes better leakage rates of the sealing system and higher blow out safety!

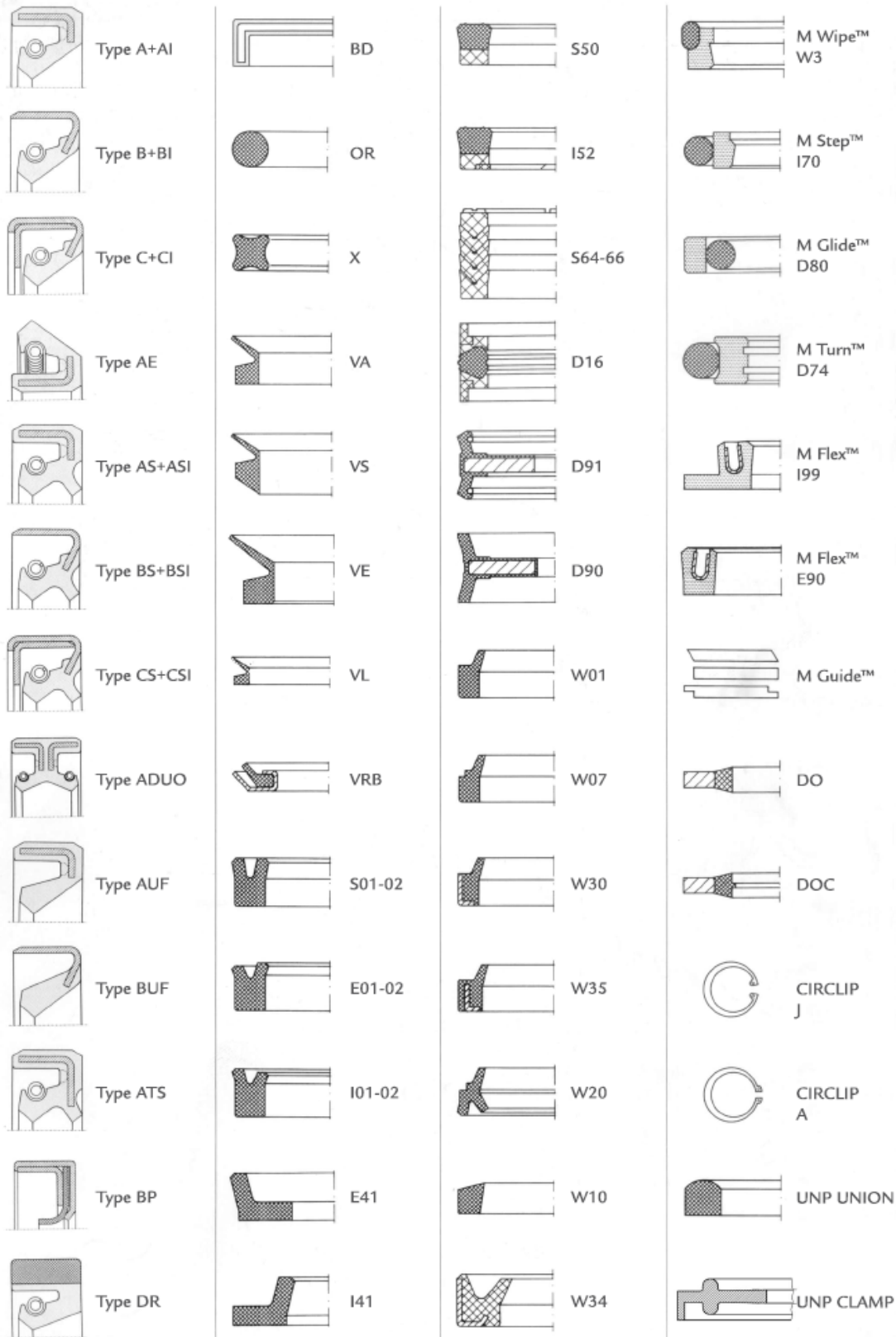

005051.VER2

M SEALS

Denmark

M Seals A/S
Bybjergvej 13
DK-3060 Espergærde
Tel.: +45 49 13 02 05
Fax: +45 49 13 01 41
sales@m-seals.dk
www.m-seals.dk

Sweden

M Seals AB
Montörgatan 7
SE-302 60 Halmstad
Tel.: +46 (0)35 15 89 40
Fax: +46 (0)35 12 19 47
sales@m-seals.se
www.m-seals.se

China

M Seals China
Room 2508, Starlife Building
Wangjing West
Chaoyang District
Beijing 100102, China
Tel.: +86 10 8453 7121
Fax: +86 10 6475 0529
msealschina@gmail.com
www.m-seals.com