

GUIDE RINGS

ACETAL (POM)



General

A standard range of Guide Rings produced from reinforced acetal resin and manufactured to closely controlled tolerances.

There are two versions available:

- E/DWR for pistons application where dynamic contact is on the outside diameter.
- I/DWR for rods or shafts where dynamic contact is on the internal diameter.

The main characteristics of both types are:

- simple manufacture of groove and assembly
- high mechanical strength and resistance to heavy radial loads
- low break-out and running coefficient of friction (between 0.05 and 0.1 on steel when lubricated)
- large selection of sizes.

Operating conditions

Both types are widely used for controlling piston and shaft concentricity in pneumatic and hydraulic equipment.

They are particularly suitable for replacing traditional soft metal bearings as their low friction benefits, enable them to operate effectively in conditions of minimal lubrication. E/DWR and I/DWR rings are recommended for use within the following conditions:

- Temperature - 40°C to + 130°C
- Fluids mineral based fluids, water/glycol, water emulsions, phosphate esters (non-flammable)
- Fluid pressure: no limitation
- Radial load in normal lubricated conditions and speeds up to 30 m/min the maximum radial load can be calculated from the formula:

$$P = D \times E \times P_s$$

where

P	(Kg)	Max radial load
D	(cm)	Ring diameter subject to dynamic movement
E	(cm)	Ring axial width
P _s	(Bar)	370 Bar (ASTM D.695) maximum permissible loading for material.

Housing grooves

The nominal dimensions and tolerances are given in the housing tables.

When the Guide Rings are used in conjunction with standard seals, special attention should be made to the extrusion gaps behind the seals to ensure that these clearances do not permit extrusion, use tolerances as recommended for each application.

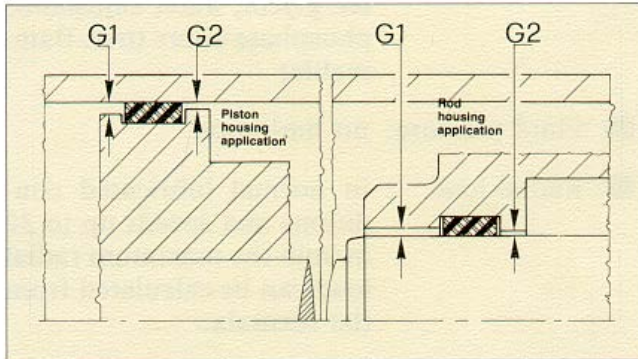

G1 = Radial gap guide ring

$$\left[\begin{array}{l} \text{piston E/DWR:} \\ \text{rod I/DWR:} \end{array} \right. \quad G1 = \frac{D - P}{2}$$

$$G1 = \frac{F - d}{2}$$

G2 = Radial gap as for the seal

Surface finish

To ensure long life of the guide rings the surface finishes must not exceed those indicated for the seal being used.

Summary

In the free condition, the guide rings are split and will naturally spring out of round. To avoid potential damage during assembly, recommended lead-in chamfers should be incorporated in the end of the cylinder bore or rod ends for E/DWR and I/DWR respectively.

Details of lead-in chamfers are given for the specific seals and the relevant catalogue will recommended the correct details.

Assembly

No special instructions are necessary although some lubrication is desirable and attention to cleanliness is important.

Hydrodynamic pressure

Whenever fluid is introduced between two moving parts, and rotary or reciprocating movement is involved, it is possible to induce increased pressures at this point depending upon the following variables:

ν = dynamic fluid viscosity

v = relative velocity

l = bearing length

G = radial clearance between mating parts

The increase in pressure can be calculated with some accuracy by the following formula:

$$\Delta P = \frac{6\nu \times v \times l}{G^2}$$

Using this formula it can be demonstrated that where mating parts fit extremely tightly, pressure can be generated that will seriously affect the seals and cylinder operation.

This problem is eliminated with I/DWR bearing by significantly reducing the length of bearing and allowing passage of fluid through the split in the ring.

Where soft metal bearings are employed axial or helical grooves may be necessary to overcome this phenomena.

Dimension table E/DWR

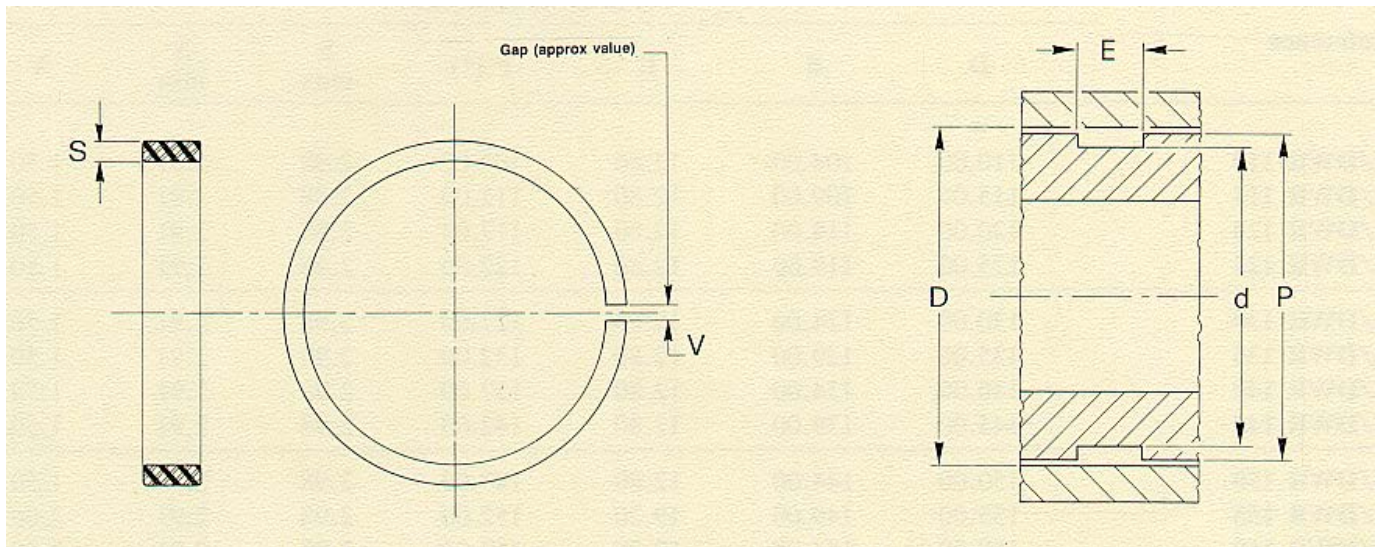

Nominal dimension tolerances

D nominal	D	d	E	P
15 ÷ 50		+ 0.00 - 0.10		
51 ÷ 180	ISO (H 11)	+ 0.00 - 0.20	+ 0.10 - 0.00	± 0.05
181 ÷ 300		+ 0.00 - 0.30		

Nominal dimensions

Reference	D	d	E	P (*)	S max.	S min.	V
E/DWR 16/2	16.00	12.00	9.60	14.00	1.97	1.92	1.00
E/DWR 20/2	20.00	16.00	9.60	18.00	1.97	1.92	1.00
E/DWR 25/2	25.00	21.00	9.60	23.00	1.97	1.92	1.00
E/DWR 30/2	30.00	26.00	9.60	28.00	1.97	1.92	1.00
E/DWR 32/2	32.00	28.00	9.60	30.00	1.97	1.92	1.00
E/DWR 35/2	35.00	31.00	9.60	33.00	1.97	1.92	1.00
E/DWR 40/2	40.00	36.00	9.60	38.00	1.97	1.92	1.00
E/DWR 45/2	45.00	41.00	9.60	43.00	1.97	1.92	1.00
E/DWR 50	50.00	44.00	9.60	47.00	2.98	2.91	1.50
E/DWR 55	55.00	49.00	12.80	52.00	2.98	2.91	1.50
E/DWR 60	60.00	54.00	12.80	57.00	2.98	2.91	1.50
E/DWR 65	65.00	59.00	12.80	62.00	2.98	2.91	1.50
E/DWR 70	70.00	64.00	12.80	67.00	2.98	2.91	1.50
E/DWR 75	75.00	69.00	12.80	72.00	2.98	2.91	1.50
E/DWR 80	80.00	74.00	12.80	77.00	2.98	2.91	1.50
E/DWR 85	85.00	79.00	12.80	82.00	2.98	2.91	1.50
E/DWR 90	90.00	84.00	12.80	87.00	2.98	2.91	1.50
E/DWR 95	95.00	89.00	12.80	92.00	2.98	2.91	1.50
E/DWR 100	100.00	94.00	12.80	97.00	2.98	2.91	1.50
E/DWR 105	105.00	99.00	12.80	102.00	2.98	2.91	1.50

(*) Value applicable in accordance with recommendations as detailed in Housing grooves on page 3.

Dimension table E/DWR

Reference	Nominal dimensions						
	D	d	E	P (*)	S max.	S min.	V
E/DWR 110	110.00	104.00	12.80	107.00	2.98	2.91	1.50
E/DWR 115	115.00	109.00	12.80	112.00	2.98	2.91	1.50
E/DWR 120	120.00	114.00	12.80	117.00	2.98	2.91	1.50
E/DWR 125	125.00	119.00	12.80	122.00	2.98	2.91	1.50
E/DWR 130	130.00	124.00	12.80	127.00	2.98	2.91	1.50
E/DWR 135	135.00	129.00	12.80	132.00	2.98	2.91	1.50
E/DWR 140	140.00	134.00	12.80	137.00	2.98	2.91	1.50
E/DWR 145	145.00	139.00	12.80	142.00	2.98	2.91	1.50
E/DWR 150	150.00	144.00	12.80	147.00	2.98	2.91	1.50
E/DWR 155	155.00	149.00	19.20	152.00	2.98	2.91	2.00
E/DWR 160	160.00	154.00	19.20	157.00	2.98	2.91	2.00
E/DWR 165	165.00	159.00	19.20	162.00	2.98	2.91	2.00
E/DWR 170	170.00	164.00	19.20	167.00	2.98	2.91	2.00
E/DWR 175	175.00	169.00	19.20	172.00	2.98	2.91	2.00
E/DWR 180	180.00	174.00	19.20	177.00	2.98	2.91	2.00
E/DWR 185	185.00	179.00	19.20	182.00	2.98	2.91	2.00
E/DWR 190	190.00	184.00	19.20	187.00	2.98	2.91	2.00
E/DWR 195	195.00	189.00	19.20	192.00	2.98	2.91	2.00
E/DWR 200	200.00	194.00	19.20	197.00	2.98	2.91	2.00
E/DWR 205	205.00	199.00	19.20	202.00	2.98	2.91	2.00
E/DWR 210	210.00	204.00	19.20	207.00	2.98	2.91	2.00
E/DWR 215	215.00	209.00	19.20	212.00	2.98	2.91	2.00
E/DWR 220	220.00	214.00	19.20	217.00	2.98	2.91	2.00
E/DWR 225	225.00	219.00	19.20	222.00	2.98	2.91	2.00
E/DWR 230	230.00	224.00	19.20	227.00	2.98	2.91	2.00
E/DWR 235	235.00	229.00	19.20	232.00	2.98	2.91	2.00
E/DWR 240	240.00	234.00	19.20	237.00	2.98	2.91	2.00
E/DWR 245	245.00	239.00	19.20	242.00	2.98	2.91	2.00
E/DWR 250	250.00	244.00	19.20	247.00	2.98	2.91	2.00
E/DWR 255	255.00	249.00	19.20	252.00	2.98	2.91	2.00
E/DWR 260	260.00	254.00	19.20	257.00	2.98	2.91	2.00
E/DWR 265	265.00	259.00	19.20	262.00	2.98	2.91	2.00
E/DWR 270	270.00	264.00	19.20	267.00	2.98	2.91	2.00
E/DWR 275	275.00	269.00	19.20	272.00	2.98	2.91	2.00
E/DWR 280	280.00	274.00	19.20	277.00	2.98	2.91	2.00
E/DWR 285	285.00	279.00	19.20	282.00	2.98	2.91	2.00
E/DWR 290	290.00	284.00	19.20	287.00	2.98	2.91	2.00
E/DWR 295	295.00	289.00	19.20	292.00	2.98	2.91	2.00
E/DWR 300	300.00	294.00	19.20	297.00	2.98	2.91	2.00

(*) Value applicable in accordance with recommendations as detailed in Housing grooves on page 3.

Note: The guide ring E/DWR's important dimensions are the width and cross section and these vary according to the ring diameter. Due to the tolerances applied the width and cross section may be larger than the S value indicated in the table.

Dimension table I/DWR

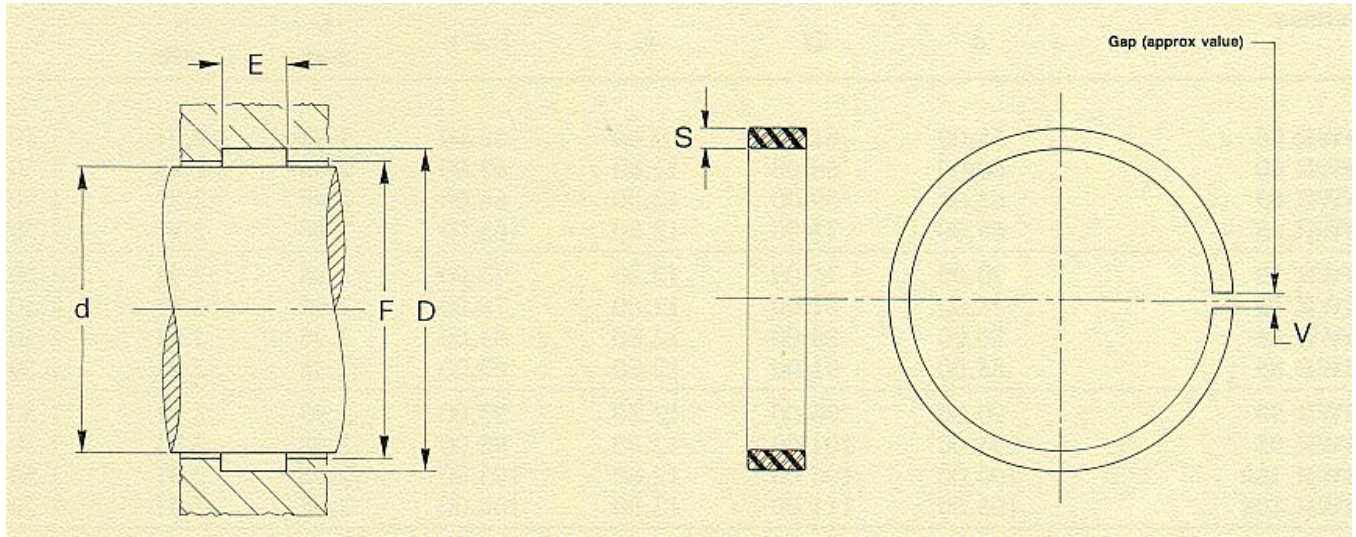

Nominal dimension tolerances

d nominal	d	D	E	F
12 ÷ 50		- 0.00 + 0.10		
51 ÷ 180	ISO (h 11)	- 0.00 + 0.20	+ 0.10 - 0.00	±0.05
181 ÷ 300		- 0.00 + 0.30		

Nominal dimensions

Reference	d	D	E	F (*)	S max.	S min.	V
I/DWR 12/2	12.00	16.00	9.60	14.00	1.97	1.92	1.00
I/DWR 14/2	14.00	18.00	9.60	16.00	1.97	1.92	1.00
I/DWR 16/2	16.00	20.00	9.60	18.00	1.97	1.92	1.00
I/DWR 18/2	18.00	22.00	9.60	20.00	1.97	1.92	1.00
I/DWR 20/2	20.00	24.00	9.60	22.00	1.97	1.92	1.00
I/DWR 22/2	22.00	26.00	9.60	24.00	1.97	1.92	1.00
I/DWR 25/2	25.00	29.00	9.60	27.00	1.97	1.92	1.00
I/DWR 26/2	26.00	30.00	9.60	28.00	1.97	1.92	1.00
I/DWR 28/2	28.00	32.00	9.60	30.00	1.97	1.92	1.00
I/DWR 30/2	30.00	34.00	9.60	32.00	1.97	1.92	1.00
I/DWR 32/2	32.00	36.00	9.60	34.00	1.97	1.92	1.00
I/DWR 35/2	35.00	39.00	9.60	37.00	1.97	1.92	1.00
I/DWR 36/2	36.00	40.00	9.60	38.00	1.97	1.92	1.00
I/DWR 38/2	38.00	42.00	9.60	40.00	1.97	1.92	1.00
I/DWR 40/2	40.00	44.00	9.60	42.00	1.97	1.92	1.00
I/DWR 45	45.00	51.00	9.60	48.00	2.98	2.91	1.50
I/DWR 46	46.00	52.00	9.60	49.00	2.98	2.91	1.50
I/DWR 48	48.00	54.00	9.60	51.00	2.98	2.91	1.50
I/DWR 50	50.00	56.00	9.60	53.00	2.98	2.91	1.50
I/DWR 53	53.00	59.00	9.60	56.00	2.98	2.91	1.50

(*) Value applicable in accordance with recommendations as detailed in Housing grooves on page 3.

Dimension table I/DWR

Reference	Nominal dimensions						
	d	D	E	F (*)	S max.	S min.	V
I/DWR 55	55.00	61.00	9.60	58.00	2.98	2.91	1.50
I/DWR 60	60.00	66.00	12.80	63.00	2.98	2.91	1.50
I/DWR 63	63.00	69.00	12.80	66.00	2.98	2.91	1.50
I/DWR 65	65.00	71.00	12.80	68.00	2.98	2.91	1.50
I/DWR 70	70.00	76.00	12.80	73.00	2.98	2.91	1.50
I/DWR 75	75.00	81.00	12.80	78.00	2.98	2.91	1.50
I/DWR 80	80.00	86.00	12.80	83.00	2.98	2.91	1.50
I/DWR 85	85.00	91.00	12.80	88.00	2.98	2.91	1.50
I/DWR 90	90.00	96.00	12.80	93.00	2.98	2.91	1.50
I/DWR 95	95.00	101.00	12.80	98.00	2.98	2.91	1.50
I/DWR 100	100.00	106.00	12.80	103.00	2.98	2.91	1.50
I/DWR 105	105.00	111.00	12.80	108.00	2.98	2.91	1.50
I/DWR 110	110.00	116.00	12.80	113.00	2.98	2.91	1.50
I/DWR 115	115.00	121.00	12.80	118.00	2.98	2.91	1.50
I/DWR 120	120.00	126.00	12.80	123.00	2.98	2.91	1.50
I/DWR 125	125.00	131.00	12.80	128.00	2.98	2.91	1.50
I/DWR 130	130.00	136.00	12.80	133.00	2.98	2.91	1.50
I/DWR 135	135.00	141.00	12.80	138.00	2.98	2.91	1.50
I/DWR 140	140.00	146.00	12.80	143.00	2.98	2.91	1.50
I/DWR 145	145.00	151.00	12.80	148.00	2.98	2.91	1.50
I/DWR 150	150.00	156.00	12.80	153.00	2.98	2.91	2.00
I/DWR 155	155.00	161.00	19.20	158.00	2.98	2.91	2.00
I/DWR 160	160.00	166.00	19.20	163.00	2.98	2.91	2.00
I/DWR 165	165.00	171.00	19.20	168.00	2.98	2.91	2.00
I/DWR 170	170.00	176.00	19.20	173.00	2.98	2.91	2.00
I/DWR 175	175.00	181.00	19.20	178.00	2.98	2.91	2.00
I/DWR 180	180.00	186.00	19.20	183.00	2.98	2.91	2.00
I/DWR 185	185.00	191.00	19.20	188.00	2.98	2.91	2.00
I/DWR 190	190.00	196.00	19.20	193.00	2.98	2.91	2.00
I/DWR 195	195.00	201.00	19.20	198.00	2.98	2.91	2.00
I/DWR 200	200.00	206.00	19.20	203.00	2.98	2.91	2.00
I/DWR 205	205.00	211.00	19.20	208.00	2.98	2.91	2.00
I/DWR 210	210.00	216.00	19.20	213.00	2.98	2.91	2.00
I/DWR 215	215.00	221.00	19.20	218.00	2.98	2.91	2.00
I/DWR 220	220.00	226.00	19.20	223.00	2.98	2.91	2.00
I/DWR 225	225.00	231.00	19.20	228.00	2.98	2.91	2.00
I/DWR 230	230.00	236.00	19.20	233.00	2.98	2.91	2.00
I/DWR 235	235.00	241.00	19.20	238.00	2.98	2.91	2.00
I/DWR 240	240.00	246.00	19.20	243.00	2.98	2.91	2.00
I/DWR 245	245.00	251.00	19.20	248.00	2.98	2.91	2.00
I/DWR 250	250.00	256.00	19.20	253.00	2.98	2.91	2.00
I/DWR 255	255.00	261.00	19.20	258.00	2.98	2.91	2.00
I/DWR 260	260.00	266.00	19.20	263.00	2.98	2.91	2.00
I/DWR 265	265.00	271.00	19.20	268.00	2.98	2.91	2.00
I/DWR 270	270.00	276.00	19.20	273.00	2.98	2.91	2.00
I/DWR 275	275.00	281.00	19.20	278.00	2.98	2.91	2.00
I/DWR 280	280.00	286.00	19.20	283.00	2.98	2.91	2.00
I/DWR 285	285.00	291.00	19.20	288.00	2.98	2.91	2.00
I/DWR 290	290.00	296.00	19.20	293.00	2.98	2.91	2.00
I/DWR 295	295.00	301.00	19.20	298.00	2.98	2.91	2.00

Note: The guide ring I/DWR's important dimensions are the width and cross section and these vary according to the ring diameter.

Due to the tolerances applied the width and cross section may be larger than the S value indicated in the table.

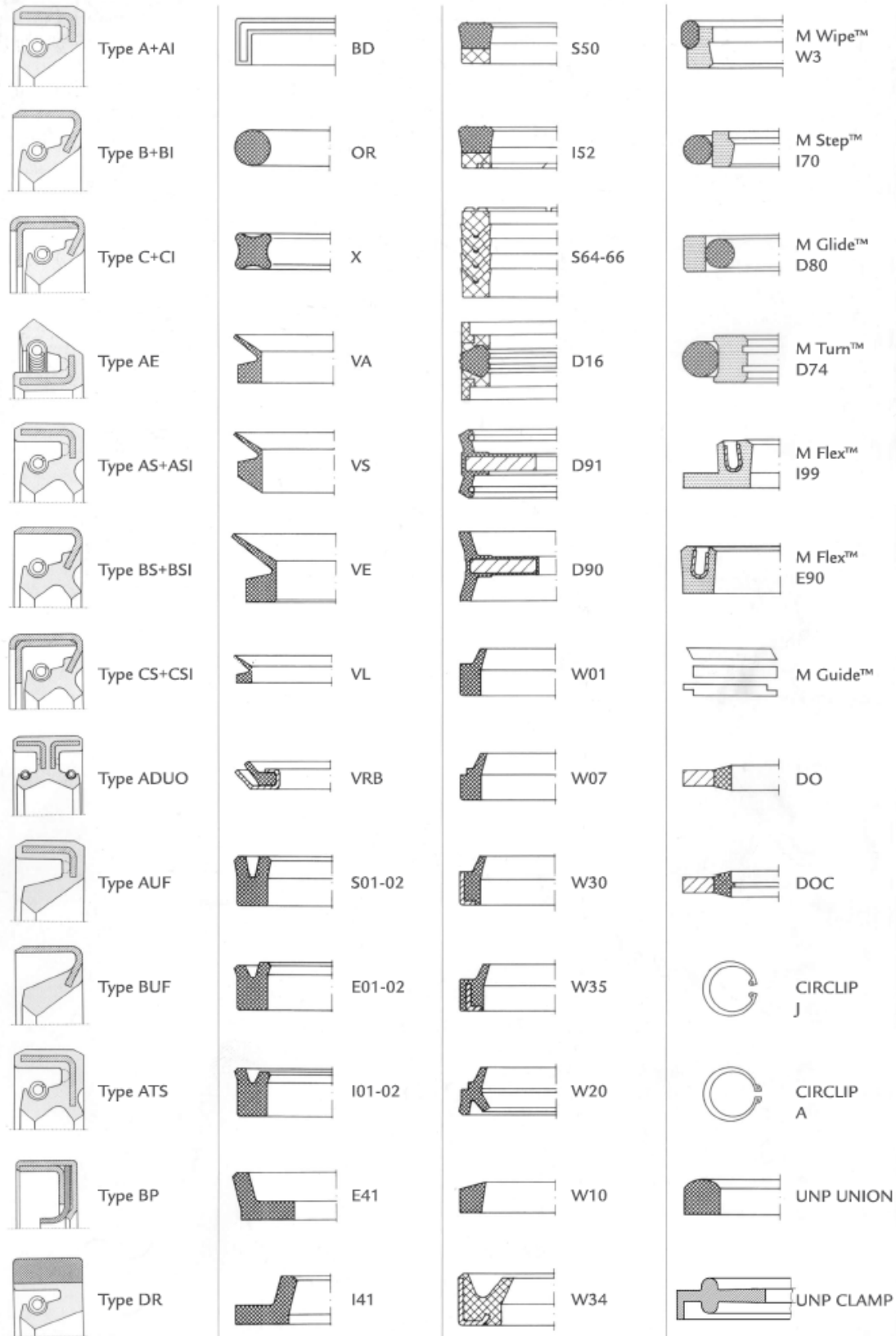

005073.VER1

M SEALS

Denmark

M Seals A/S
Bybjergvej 13
DK-3060 Espergærde
Tel.: +45 49 13 02 05
Fax: +45 49 13 01 41
sales@m-seals.dk
www.m-seals.dk

Sweden

M Seals AB
Montörgatan 7
SE-302 60 Halmstad
Tel.: +46 (0)35 15 89 40
Fax: +46 (0)35 12 19 47
sales@m-seals.se
www.m-seals.se

China

M Seals China
Room 2508, Starlife Building
Wangjing West
Chaoyang District
Beijing 100102, China
Tel.: +86 10 8453 7121
Fax: +86 10 6475 0529
msealschina@gmail.com
www.m-seals.com